



A Compact Multimedia Display Development Platform for Automotive and Industrial Markets

Xilinx FPGAs and Xylon IP cores shorten design cycles and lower production costs for multimedia applications.

by Davor Kovacec
CEO
Xylon d.o.o.
dkova@xylon.hr

Market leadership in the fast-moving electronics market continuously demands innovative and cost-effective products. With an ever-shrinking time-to-market window, design tools and pre-designed IP blocks are important elements of success.

The right development platform can make all the difference between success and failure. It is a balancing act between the contradictory requirements of having a standard but still highly configurable solution.

Combining Xilinx® FPGAs with the Xylon logicBRICKS IP cores library, Xylon's feature-rich logiCRAFT 3 compact multimedia display development platform is an ideal solution, addressing the time-to-market and flexibility needs of the high-volume customer base. You can quickly turn system designs running on this generic FPGA development platform into specialized products. Such a design approach enables a large portion of design reuse through different hardware (IP cores) and software modules. You can reuse these same modules in many system designs for different applications.

The logiCRAFT Platform

The logiCRAFT 3 compact multimedia display development platform (Figure 1) is an FPGA-based board using hardware modules in the form of IP cores to develop FPGA functionality. The platform is designed to support a wide variety of audio and video sources and handle a





Figure 1 – LogiCRAFT 3 compact multimedia display development platform

variety of display types. With several standard communication interfaces, you can easily integrate the logiCRAFT 3 platform into a larger system. Figure 2 shows logiCRAFT 3's functional blocks.

A wide variety of system interfaces such as audio/video (A/V) I/Os, line drivers, gener-

al-purpose I/Os, and COG power supplies makes this platform extremely versatile.

The logiCRAFT 3 platform is primarily aimed at the automotive market, including applications such as navigation, infotainment, rear-seat entertainment (RSE), and driver assistance. Other multimedia applications are equally applicable, such as consumer, medical, and measurement instrumentation or factory automation applications.

Figure 3 shows block schematics of an automotive RSE system. In this particular example, the logiCRAFT 3 is used in the car headrests and serves to deliver A/V content.

The platform's flexibility can help reduce overall solution costs as well as time to market. For example, the platform's capability to fully support a number of different displays enables you to make selections when required for cost or availability. Implementing high-quality wireless audio

through two embedded IR headphone audio outputs for the RSE is also an opportunity to reduce system cost. The FM modulation is implemented using the logiAIR IP core, enabling the use of a low-cost field effect transistor (FET) for IR LED driving. There is also the flexibility to enable Bluetooth with the addition of a Bluetooth module.

Audio and video streams, as well as control data, are transferred to the RSE headrest unit by using an embedded high-speed Gbps digital link. The low data-rate content, such as push-button status, remote controller data, touch-screen data, and others are transferred using the same link.

The link itself requires only two twisted pair lines. One line may also be used for powering the platform, resulting in a significant reduction in infotainment wiring costs. You can have the A/V devices connected to the logiCRAFT 3 through the composite video blanking and sync

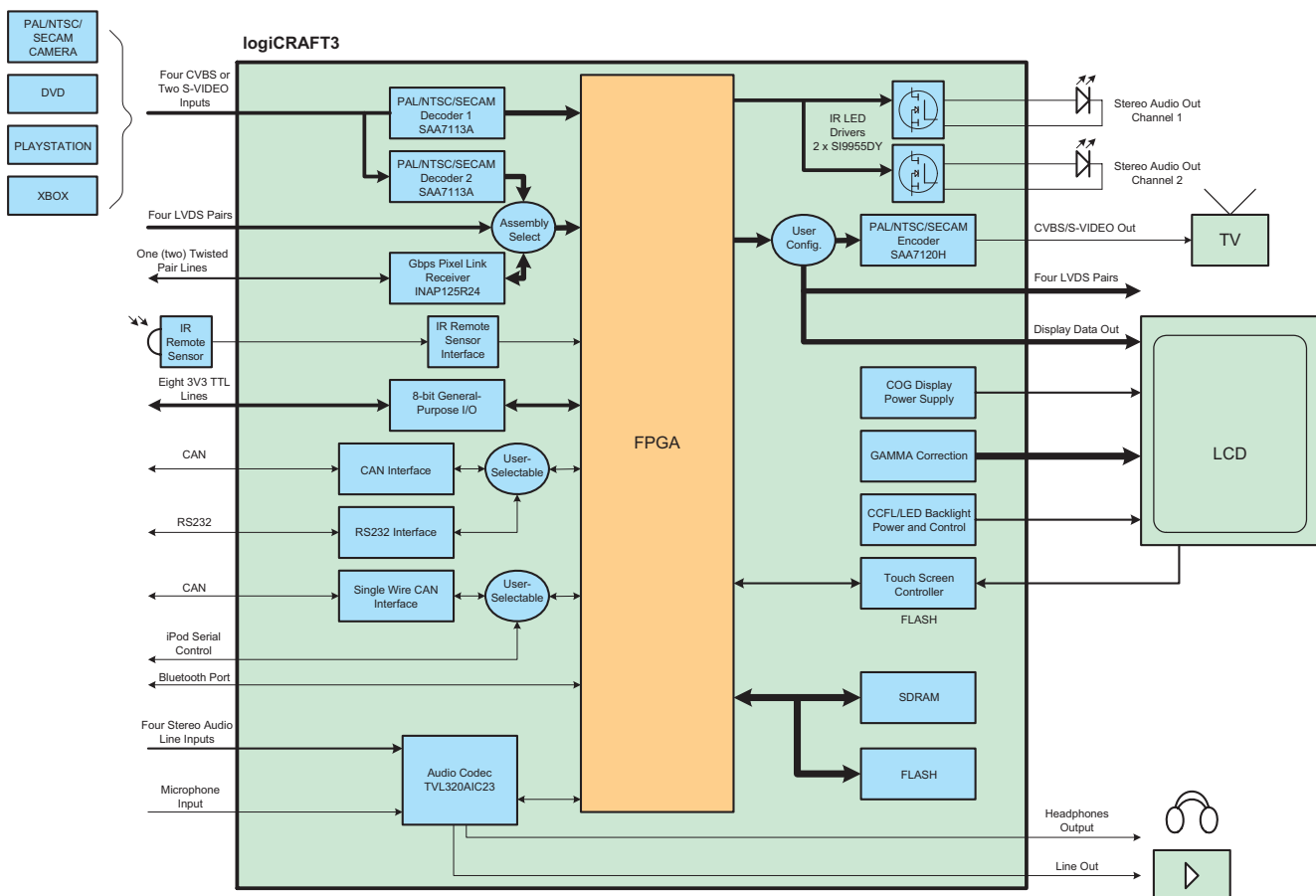

Figure 2 – LogiCRAFT 3 platform's functional blocks

(CVBS) or S-video inputs (video) and stereo line inputs (audio). An iPod can also be connected as required.

The logiCRAFT 3 platform can also be used in stand-alone human machine interface (HMI) applications such as:

- Instrument cluster applications (Figure 4)
- Car radio and navigation
- Industrial and medical instrumentation (Figure 5)

In these applications, you can use either the CAN network connection for all data transfer or the standard RS232 channel for communication and debugging. For applications requiring HMI control, an embedded IR remote control sensor, touch-screen interfaces, and GPIO for buttons and LEDs are provided.

You can also add features by using Xilinx LogiCORE™ IP, other third-party IP cores, or by designing a custom circuit.

The list of key IP cores that can be utilized on the logiCRAFT 3 includes:

- logiCVC-ML – compact multilayer video controller
- logi2D – 2-D graphics accelerator
- logiCAN – CAN 2.0B-compatible network controller
- logiUART – universal asynchronous receiver/transmitter
- logiWIN – versatile video input
- logiMEM – flexible SDRAM/DDRAM/flash memory controller
- logiI2S – I²S transceiver
- logiRC – IR remote controller receiver
- logiAIR – digital FM modulator for IR headphones

Spartan™-3E FPGA hardware resources, dedicated multipliers, digital clock managers (DCMs), and block RAMs ensure that IP cores operate at higher speeds and consume less area on the FPGA. In addition, FPGA configuration from an external byte-width memory provides fast board startup time, which is of a great importance in automotive applications. All Xylon IP cores are carefully designed for

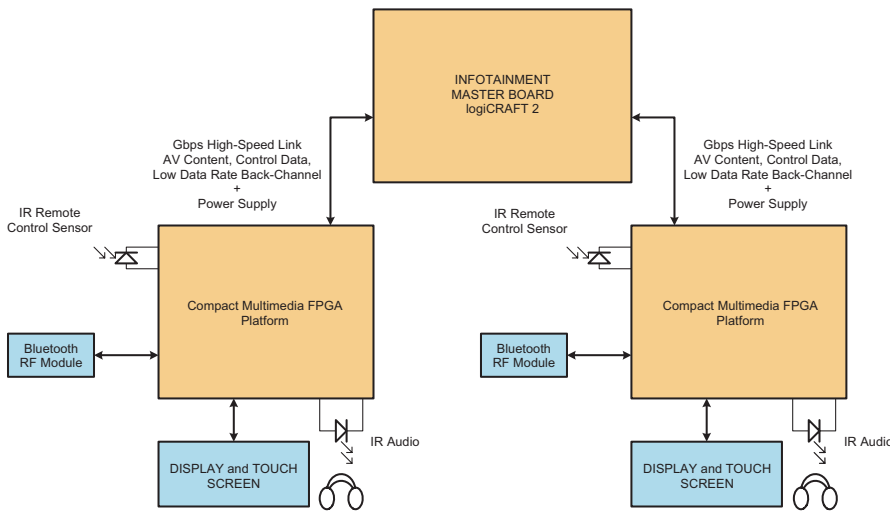

Figure 3 – Rear-seat entertainment system

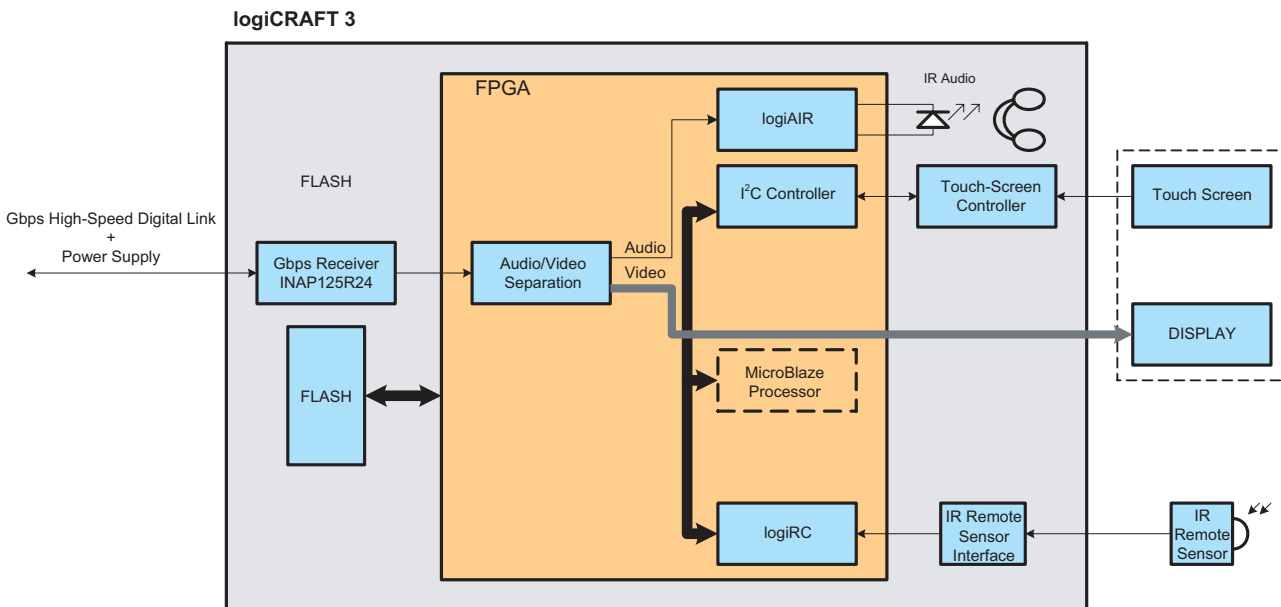

Figure 4 – Platform/FPGA structure for rear-seat entertainment application

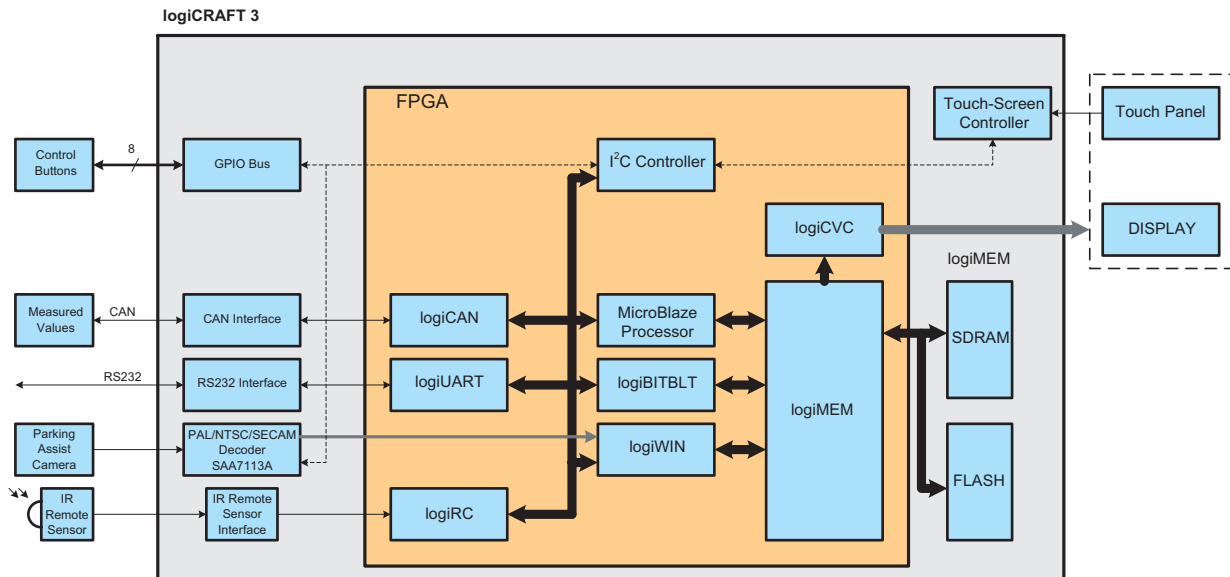

Figure 5 – Platform/FPGA structure for instrument cluster application

the lowest FPGA resource utilization, making them particularly suitable for high-volume applications.

Platform Features

- Small form factor 155 mm x 115 mm (4" x 3")
- Supports Spartan-3E 3S250E/500E/1200E 256-pin FPGAs
- 8 MB of NOR flash
- 16 MB/32-bit-wide SDRAM running up to 133 MHz
- Up to two simultaneous video inputs selectable from:
 - Four CVBS or two S-video PAL/NTSC/SECAM inputs
 - One LVDS channel (clock + three data pairs) directly connected to the FPGA
 - High-speed LVDS Gbps digital transceiver
- 8-bit general-purpose I/O
- Touch-screen controller
- CAN interface and single-wire CAN interface
- RS232 interface
- Interface to external Bluetooth module
- iPod control interface

- One stereo audio input selectable from four stereo line inputs
- Microphone input
- Audio line output
- Headphone output
- Two stereo IR headphone audio outputs
- Video output configurable as:
 - CVBS/S-video PAL/NTSC/SECAM output
 - One LVDS channel (clock + three data pairs) directly from FPGA
 - Digital RGB interface
- Power supply for COG displays, including GAMMA correction and VCOM circuits
- Power and control output for CCFL backlight inverters and LCD backlights

RSE Example

Figure 4 shows the platform/FPGA structure for an RSE application where the FPGA design is based on Xylon's IP cores. In such applications, A/V and control data is usually transferred between an infotainment master board and the electronics, which are embedded into car headrests through a number of cables.

The LogiCRAFT 3 platform, with its support for a high-speed Gbps digital link,

dramatically reduces the complexity and cost of the wiring required. You can transfer all digital video, audio, and bi-directional control data using only two twisted pair lines. You can also discard the power cable, because the platform can be powered through one of the two twisted pair lines.

Besides the reduction in wiring complexity, the logiCRAFT 3 platform also integrates many functions otherwise supported by dedicated integrated circuits into just one low-cost Spartan-3 XC3S250E FPGA. You will not need additional electronics for IR audio FM modulation, IR remote protocol decoding, or I²C bus control, among others. The logiCRAFT 3 represents an ideal solution for saving your budget without having to sacrifice anything from the set of common RSE features.

Instrument Cluster Example

Figure 5 shows the platform/FPGA structure for an instrument cluster, where the powerful yet compact logiCVC multilayer display controller will help you create a state-of-the-art instrument panel. With a 60-fps refresh rate, you will be able to animate on-screen gauges and give them the motion smoothness of their analog counterparts.

In addition, the logi2D graphic accelerator, with its bitmap image rotating capability, offers additional flexibility for instrument animation. You can easily

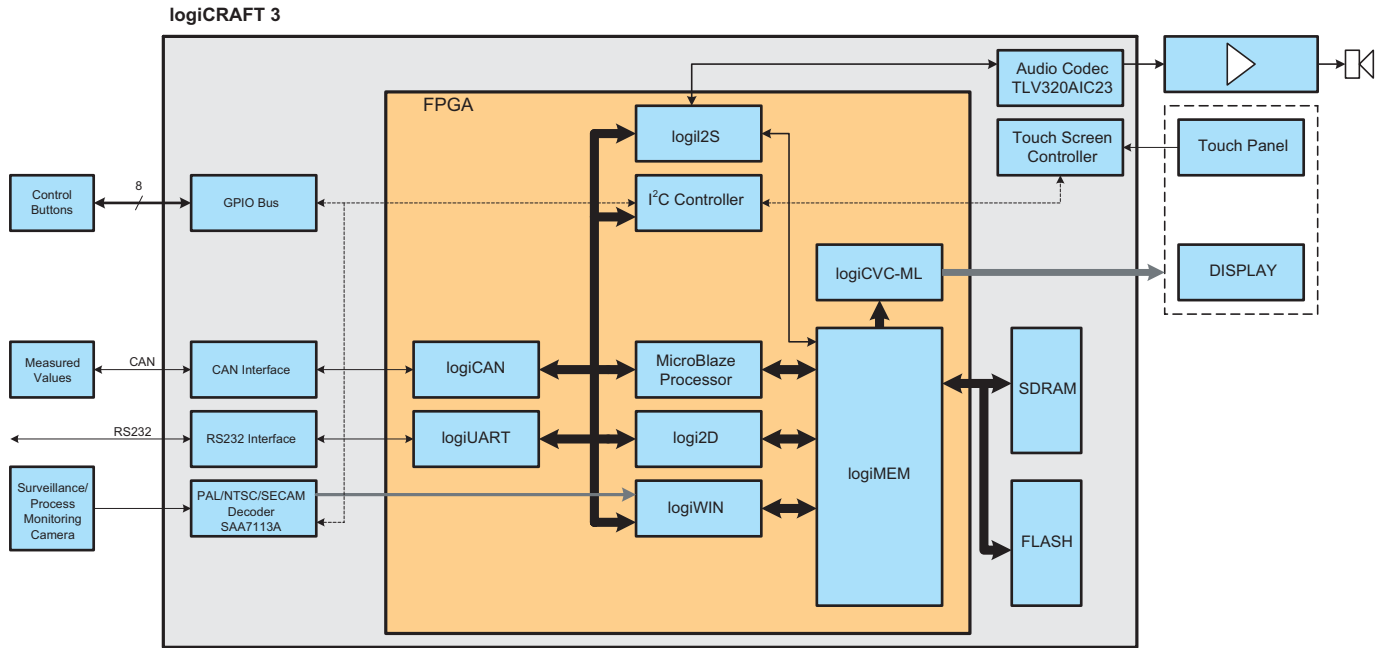

Figure 6 – Platform/FPGA structure for industrial application

design an instrument panel with GUI builder or graphic libraries to efficiently use Xylon’s graphics acceleration IP cores.

Communication between the vehicle engine control unit data and the platform is easy by using the onboard CAN interface with our logiCAN IP core. You can also connect a suitable camera using the Gbps digital link, thus adding a parking assist capability to the list of features. You can use a standard PAL/NTSC/SECAM as well.

With the help of our logiWIN IP core, you can de-interlace scale and position incoming video to optimize it for your particular display. All FPGA functionality required to support the instrument cluster configuration will fit into one Spartan-3 XC3S1200E FPGA. This way, you can achieve an outstanding cost-to-performance ratio and provide a very competitive solution for today’s demanding and fast-changing markets.

Industrial Application Example

Figure 6 shows the platform/FPGA structure where a LogiCRAFT 3 compact multimedia display development platform serves as a central unit for monitoring and controlling industrial processes, with the FPGA design based on Xylon IP cores. As in the previous example, the logiCVC/logi2D

combination, supported with dedicated graphic software libraries, gives you everything you need for making and combining screen elements required for successful process monitoring and control. You can also use an embedded touch-screen controller to make human-machine interaction intuitive and logical.

For handling classical buttons and indicators, an I²C-controlled GPIO interface is at your disposal. If your application calls for real-time environment surveillance or real-time video process monitoring, the platform’s PAL/NTSC/SECAM video decoders provide an excellent solution.

By introducing the logiWIN IP core into your FPGA configuration, you can easily handle decoded video signals in terms of de-interlacing, scaling, and positioning. The platform also provides the means to create audio alarms in an emergency situation. To implement this, you can use an embedded audio codec in combination with the logiI2S IP core. The platform-process communication can be established by using the on-board CAN interface and logiCAN IP core.

If you wish to connect the platform to a PC, you can do that through the platform’s RS 232 interface. To host all of this functionality, logiCRAFT 3 utilizes a Spartan-3

XC3S1200E FPGA, which gives you enough room to develop the optimal configuration.

However, your actual final production configuration may require less FPGA resources, so a smaller and less-expensive FPGA would suffice. The logiCRAFT 3 addresses this issue by providing pin-compatible scalability between Spartan-3 XC3S500E and XC3S250E FPGAs, thus delivering an additional feature for tailoring your final product.

Conclusion

The value of the LogiCRAFT 3 compact multimedia display development platform from Xylon lies in the high number of supported display types; the innovative system architecture, small form factor, and broad feature set; and the ability to be configured for performance, price, low development, and production cost with virtually no obsolescence.

Based on the Xilinx Spartan-3E family, with its low cost-per-gate and feature-rich architecture, the logiCRAFT 3 provides an excellent base on which to build.

For more information about the LogiCRAFT 3 compact multimedia display development platform and logicBRICKS Xylon IP library, please e-mail sales@logicbricks.com or visit www.logicbricks.com.