

Introduction

The ISOCM_V10 is an instruction-side On-Chip Memory (OCM) bus interconnect core. The core connects the PowerPC™ 405 instruction-side OCM interface to one or more peripherals, typically to the instruction-side OCM BRAM controller (ISBRAM_IF_CNTRL). For information about the PowerPC 405 OCM controller interface, see the *PowerPC 405 Processor Block Reference Guide*.

Features

- Single master - no bus arbitration logic
- Configurable multiple slave capability - contains read-data multiplexing when used with 2 or more slaves

LogiCORE™ Facts		
Core Specifics		
Supported Device Family	Virtex™-4, Virtex-II Pro	
Version of Core	isocm_v10	v2.00b
Resources Used		
	Min	Max
Slices	N/A	N/A
LUTs	0	64 ¹
FFs	0	0
Block RAMs	0	0
Provided with Core		
Documentation	Product Specification	
Design File Formats	VHDL	
Constraints File	N/A	
Verification	N/A	
Instantiation Template	N/A	
Reference Designs	N/A	
Design Tool Requirements		
Xilinx Implementation Tools	ISE 9.1i or higher	
Verification	N/A	
Simulation	ModelSim SE/PE 5.7f or higher	
Synthesis	XST	
Support		
Support provided by Xilinx, Inc.		

1. Example for 2 slaves without DCR read. Size increases with number of slaves

Functional Description

The ISOCM_V10 is an instruction-side On-Chip Memory (OCM) bus interconnect core which connects the PowerPC 405 instruction-side OCM interface to one or more peripherals. The block diagram for the core is shown in [Figure 1](#), while the core signals are listed and described in [Table 1](#).

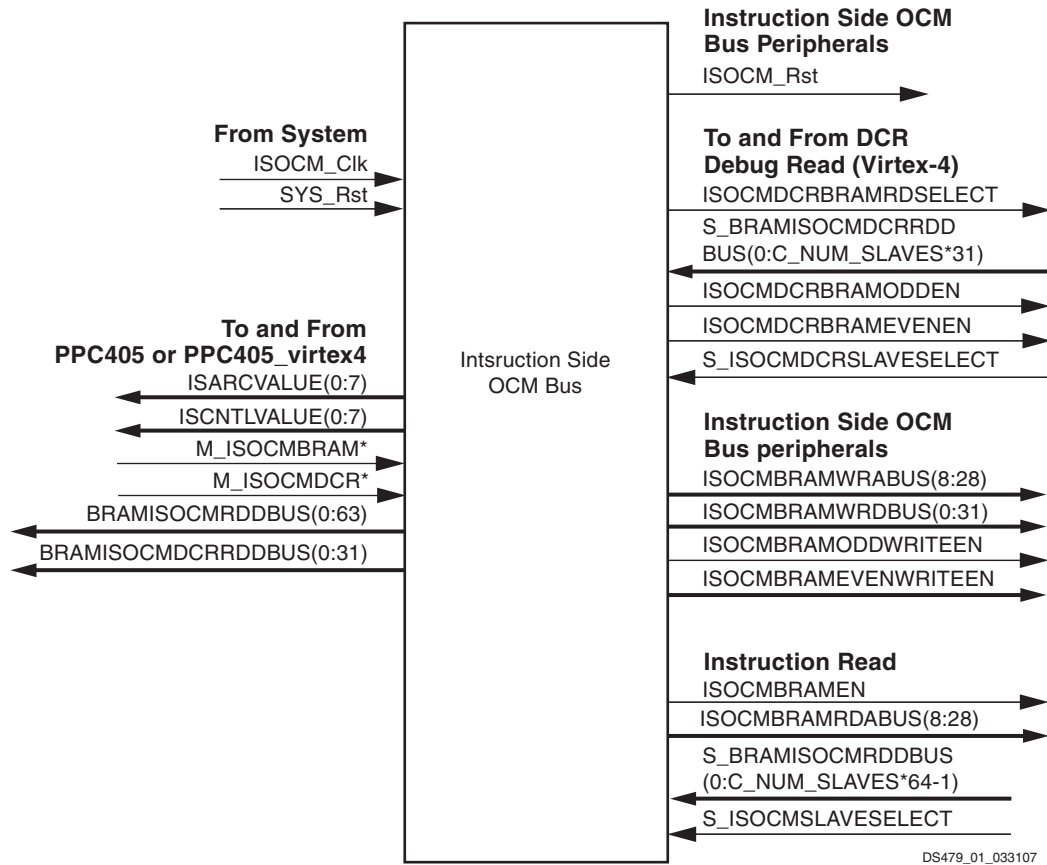

Figure 1: Instruction Side OCM Bus Block Diagram

Instruction Side OCM Bus I/O Signals

The ISOCM Bus signals are listed and described in [Table 1](#).

Table 1: Instruction Side OCM Bus I/O Signals

Signal	I/O	Connects to	Description
ISBRAMCLK	I	system	Unused
SYS_Rst	I	system	Drives the output ISOCM_RST
ISOCM_RST	O	isbram_if_cntlr	Reset signal for ISOCM BRAM interface controllers (isbram_if_cntlr)
M_ISOCMBRAM RDABUS	I	ppc405	Drives the output ISOCMBRAMRDABUS
M_ISOCMBRAM WRABUS	I	ppc405	DCR access address (ISINIT). Drives the output ISOCMBRAMWRABUS

Table 1: Instruction Side OCM Bus I/O Signals (Contd)

Signal	I/O	Connects to	Description
M_ISOCMBRAMEN	I	ppc405	Drives the output ISOCMBRAMEN
M_ISOCMBRAMWRDBUS	I	ppc405	Drives the output ISOCMBRAMWRDBUS
M_ISOCMBRAMODDWRITEEN	I	ppc405	Drives the output ISOCMBRAMODDWRITEEN
M_ISOCMBRAMEVENWRITEEN	I	ppc405	Drives the output ISOCMBRAMEVENWRITEEN
M_ISOCMDCRBRAMODDEN	I	ppc405	Drives the output ISOCMDCRBRAMODDEN (Virtex-4 only)
M_ISOCMDCRBRAMEVENEN	I	ppc405	Drives the output ISOCMDCRBRAMEVENEN (Virtex-4 only)
M_ISOCMDCRBRAMRDSELECT	I	ppc405	Drives the output ISOCMDCRBRAMRDSELECT (Virtex-4 only)
S_BRAMISOCMRDDBUS	I	isbram_if_cntlr	Drives the output BRAMISOCMRDDBUS
S_BRAMISOCMDCRRDDBUS	I	isbram_if_cntlr	Drives the output BRAMISOCMDCRRDDBUS (Virtex-4 only)
S_ISOCMSLAVESELECT	I	isbram_if_cntlr	Acknowledge signal from addressed slave. Used as a read-data valid for S_BRAMISOCMRDDBUS in multi-slave system
S_BRAMISOCMDCRSLAVESELECT	I	isbram_if_cntlr	Acknowledge signal from addressed slave. Used as a read-data valid for S_BRAMISOCMDCRRDDBUS in multi-slave system (Virtex-4 only)
BRAMISOCMRDDBUS	O	ppc405	Instruction read data
ISARCVALUE	O	ppc405	ISOCM 16MB address window offset. The signal value is defined by C_ISARCVALUE
ISCNTLVALUE	O	ppc405	ISOCM setup. The signal value is defined by the parameter C_ISCNTLVALUE
ISOCMBRAMEN	O	isbram_if_cntlr	Instruction BRAM enable
ISOCMBRAMWRDBUS	O	isbram_if_cntlr	DCR write data using ISFILL
ISOCMBRAMODDWRITEEN	O	isbram_if_cntlr	DCR write enable using ISINIT(29)
ISOCMBRAMEVENWRITEEN	O	isbram_if_cntlr	DCR write enable using ISINIT(29)
ISOCMBRAMRDABUS	O	isbram_if_cntlr	Instruction fetch address
ISOCMBRAMWRABUS	O	isbram_if_cntlr	DCR write address using ISINIT(8:28)

Table 1: Instruction Side OCM Bus I/O Signals (Contd)

Signal	I/O	Connects to	Description
ISOCMDCRBRAM ODDEN	O	isbram_if_cntlr	DCR enable using ISINIT(29) (Virtex-4 only)
ISOCMDCRBRAM EVENEN	O	isbram_if_cntlr	DCR enable using ISINIT(29) (Virtex-4 only)
ISOCMDCRBRAM RDSELECT	O	isbram_if_cntlr	DCR enable using ISINIT(29) (Virtex-4 only)
BRAMISOCMDCR RddbUS	O	ppc405	DCR read data for ISFILL (Virtex-4 only)

For information about the OCM controller interface feature, see the *PowerPC 405 Processor Block Reference Guide*.

Instruction Side OCM Bus Parameters

The ISOCM Bus parameters are listed and described in [Table 2](#).

Table 2: Instruction Side OCM Bus Parameters

Parameter	Description	Default	Tool Calculated	Type
C_NUM_ MASTERS	Number of ISOCM masters. The only allowed value is 1	1	Yes	integer
C_NUM_ SLAVES	Number of ISOCM slaves	1	Yes	integer
C_ISARC VALUE	Power-on address offset for the 16 MB ISOCM address window relative to PLB address range. E.g. with C_ISARCVAlUE=0x54, the ISOCM memory window will reside in the address range: 0x5400_0000-0x54FF_FFFF.	0x30	Yes	std_logic_ vector
C_ISCNtl VALUE	Power-on configuration of the <i>PowerPC</i> ISOCM interface controller. For details please refer to " <i>PowerPC 405 Block Reference Guide</i> ".	0x81	Yes	std_logic_ vector

Allowable Parameter Combinations

There are no restrictions on allowed parameter combinations in this core.

Parameter - Port Dependencies

The ISOCM bus parameter-port dependencies are listed and described in [Table 3](#).

Table 3: Port and parameter dependencies

Name	Affects	Depends	Relationship Description
Design Parameters			
C_NUM_SLAVES	S_BRAMISOCM RDDBUS	0 to C_NUM _SLAVES*64-1	Scale width of OCM read data bus based on number of connected slaves
C_NUM_SLAVES	S_BRAMISOCM DCRRDDBUS	0 to C_NUM _SLAVES*32-1	Scale width of DCR read data bus based on number of connected slaves
C_NUM_SLAVES	S_ISOCMSLAVE SELECT	0 to C_NUM _SLAVES	Scale width of OCM slave select based on number of connected slaves
C_NUM_SLAVES	S_BRAMISOCMD CRSLAVESELECT	0 to C_NUM _SLAVES	Scale width of DCR slave select based on number of connected slaves
Port Signals			
S_BRAMISOCMR DDBUS		C_NUM_SLAVES	Scale width of OCM read data bus based on number of connected slaves
S_BRAMISOCMD CRRDDBUS		C_NUM_SLAVES	Scale width of DCR read data bus based on number of connected slaves
S_ISOCMSLAVES ELECT		C_NUM_SLAVES	Scale width of OCM slave select based on number of connected slaves
S_BRAMISOCMD CRSLAVESELECT		C_NUM_SLAVES	Scale width of DCR slave select based on number of connected slaves

Multi-Slave Configuration

This version of the bus can handle multiple slaves. Slave address ranges must be non-overlapping and each slave core is responsible for its own address range check. All readable slaves must follow one of two methods for returning data:

1. Provide an acknowledge signal (S_ISOCMSLAVESELECT and S_ISOCMDCRSLAVESELECT) which they raise when addressed. When not addressed these signals must be held low. The slave read-data is ignored when the acknowledge is low. The ISOCM bus use the acknowledge signal as a valid signal to multiplex read-data.
1. Always provide a high acknowledge signal, but drive all 0's on read-data when not addressed.

Instruction Side OCM Bus Register Descriptions

There are no registers in this core.

Instruction Side OCM Bus Interrupt Descriptions

There are no interrupts associated with this core.

Design Implementation

Design Tools

The Instruction Side OCM Bus design is handwritten.

Xilinx XST is the synthesis tool used for synthesizing the Instruction Side OCM Bus.

Target Technology

The intended target technology is a Virtex-II Pro or a Virtex-4 FPGA.

Device Utilization and Performance Benchmarks

Table 4: ISOCM_V10 Bus Resource Utilization

Parameters	DCR read back (Virtex-4 only)	Resources	
		Flip-Flops	4-input LUTs
C_NUM_SLAVES = 1	-	0	0
C_NUM_SLAVES = 2	No	0	64
	Yes	0	96
C_NUM_SLAVES = 3	No	0	128
	Yes	0	196

There are no performance benchmarks available.

Specification Exceptions

Not applicable.

Reference Documents

UG018PowerPC 405 Processor Block Reference Guide

DS446Instruction Side OCM BRAM Interface Controller Data Sheet

Revision History

The following table shows the revision history for this document.

Date	Version	Revision
1/23/07	1.0	Initial Xilinx release