

Achieving High Performance DDR3 Data Rates

By: Adrian Cosoroaba

Programmable devices frequently require an external memory interface to buffer data that exceeds the capacity of the device's internal memory. This memory interface can often dictate overall system performance because it must provide sufficient read/write bandwidth to keep up with the flow of data.

This I/O performance requirement translates into the need for higher memory interface bandwidths with each new generation of programmable devices. In addition to higher performance, the memory interface solution also needs to be flexible and easy to implement. In many ways, the memory controller and interface design determines the capability of the overall system.

This white paper describes various memory interface and controller design challenges. It highlights the capabilities of the Xilinx 28 nm All Programmable solutions that achieve 1.866 Gb/s DDR3 data rates—namely Virtex[®]-7 and Kintex[®]-7 FPGAs and a select number of Zynq[®]-7000 All Programmable SoCs (AP SoCs).

Memory Interface Trends and Xilinx Solutions

With each generation of double data rate (DDR) SDRAMs, the data rate per pin has increased to satisfy higher system performance requirements.

Memory controller implementations have been challenged to keep up with these trends. There are two important aspects of the interface and controller implementation that present challenges in conjunction with these higher data rates:

- Read data capture in the physical layer (PHY)
- Controller implementation in the interconnect logic.

Read Data Capture

Read data capture becomes challenging when data rates increase because the read data valid window gets smaller and timing margins shrink. The I/O block and clocking elements need to provide a precise capture mechanism, and the data capture clock has to be maintained within the data valid window, even in an environment where voltages and temperatures are inconstant. See [Figure 1](#).

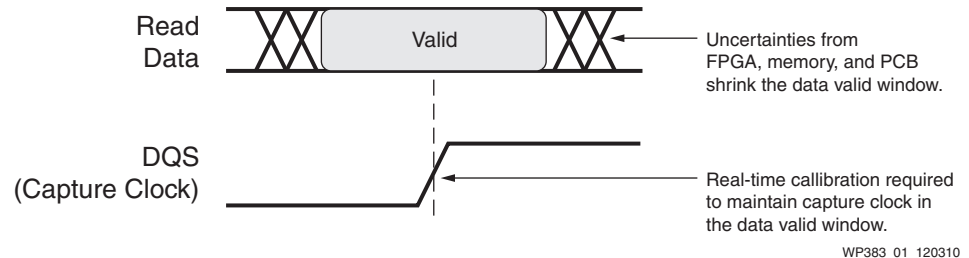

Figure 1: Clock to Data and the Real-Time Calibration Challenge

Therefore, increasing data rates and shrinking timing margins create a requirement for a more precise clocking and calibration system. Such a system needs to provide a robust mechanism for real-time calibration, ensuring that the capture clock (DQS) is maintained within the data valid window with sufficient setup and hold margins under varying system conditions. A new clocking architecture element called the Phaser, when controlled by the calibration logic, provides real-time temperature compensation capability at 1.866 Gb/s data rates for Virtex-7 and Kintex-7 mid speed grade FPGAs, as well as Zynq Z-7030, Z-7045, and Z-7100 devices.

Controller Implementation

A second and equally challenging aspect of the design is the logic-fabric-based implementation of the memory controller. With increasing DDR memory data rates (2X the memory clock rate), the logic-fabric-based controller that manages memory commands and data flow must run at higher rates as well. With each successive device generation, the memory clock rates for each DDR architecture generation have increased at a faster pace than logic fabric performance, creating a gap between required memory clock rates and the rates at which logic-fabric-based controllers can be clocked (see [Figure 2](#)). To address these challenges, Xilinx has created innovative solutions.

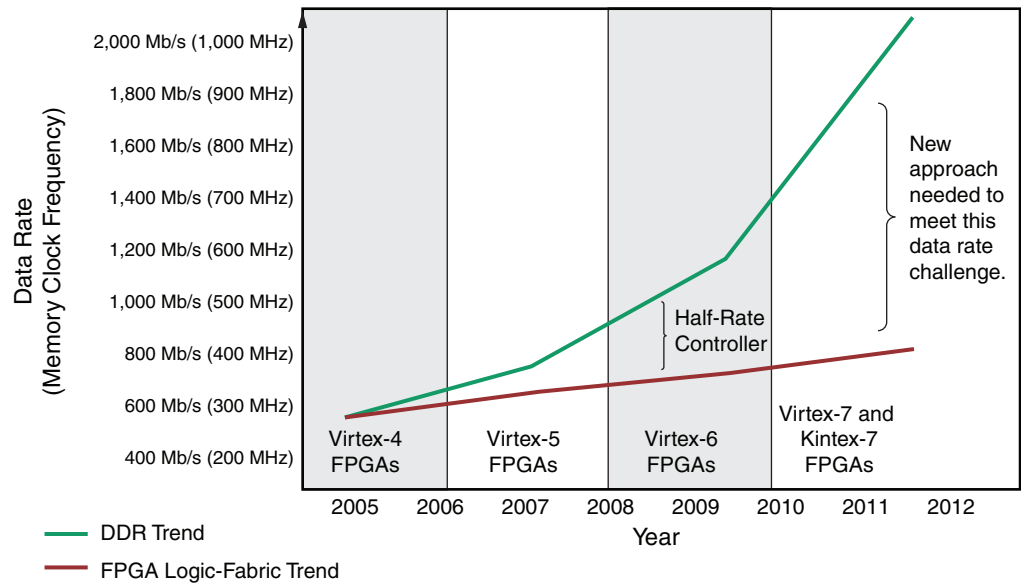

Figure 2: Data Rate Challenge for Logic-Fabric-Based Controllers

In previous-generation products (such as Virtex-6 FPGAs), a DDR3 controller running at half the rate of the memory clock is implemented to meet the logic fabric timing limitations. This implementation provides a good match between the data rate capabilities of the I/O and the logic fabric clock rate capabilities needed for the controller implementation.

In the 7 series and Zynq devices, however, a new architecture bridges the wider gap between DDR3 data rates of up to 1.866 Gb/s (needed in high-performance applications) and the logic fabric clock rate.

Memory Interface Architecture

Xilinx has improved the architecture of the PHY layer memory interface and controllers to achieve data rates of 1.866 Gb/s for mid speed grade FPGAs and AP SoCs. The efficiency of the DDR3 controller design has also been improved to achieve higher effective bandwidth.

As shown in Figure 3, the architecture of the memory controller and interface incorporates three functional modules: the PHY, the DDR3 memory controller, and the user interface.

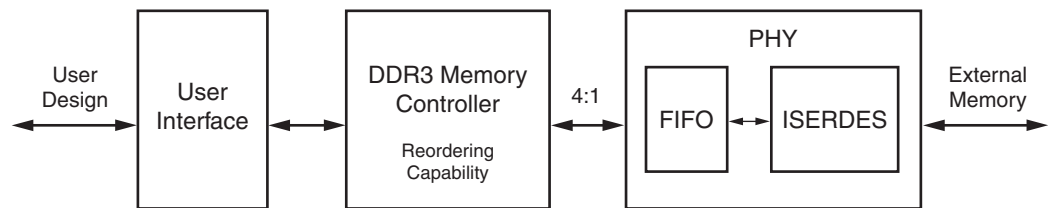

Figure 3: DDR3 Controller and Interface Architecture

For DDR3 interfaces that run at a data rate of 1.866 Gb/s, the clock rate of the logic-fabric-based controller needs to be ¼ the memory clock rate to implement controller state machines in the logic fabric that can keep up with the 933 MHz DDR3

memory clock rate. The improved PHY architecture makes this possible with a dedicated FIFO that provides the gearbox capability to decouple the memory clock rate from the logic-fabric-based controller clock rate at an appropriate ratio. This ratio can be 4:1, or for lower memory clock rates, 2:1. DDR3 interfaces that require clock rates of over 800 MHz (1,600 Mb/s) are suitable for 4:1 decoupling ratios, while other interfaces like QDR-II+ or RLDRAM II running at rates below 550 MHz can be better matched with a 2:1 decoupling ratio.

Optimizing the Physical Layer for Higher Data Rates

The PHY is responsible for capturing read data and for transferring write data from the controller to the external memory devices. The I/O drivers must provide sufficient drive strength and switching speed for data rates up to 1.866 Gb/s supported by the highest speed grade DDR3 devices. An innovative I/O architecture ensures drive capability with excellent signal integrity at these high rates. A 2V pre-driver voltage option (V_{CCAUX_IO}) was needed to ensure sufficient signal gain to meet the drive requirements for the 1.866 Gb/s rates. See [Figure 4](#).

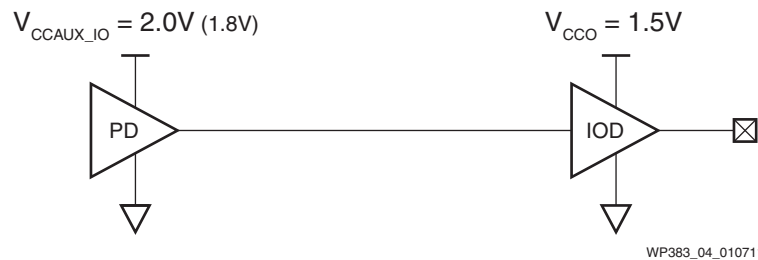

Figure 4: 2.0V Pre-driver (V_{CCAUX_IO}) Voltage Supply Option

In addition to enabling the capabilities of the I/O driver and receiver to switch at these high data rates, the read data capture and real-time calibration require a dedicated clocking circuit that can manage the initial calibration of the clock to the data valid window and maintain this relationship over changes in voltage and temperature during system operation. 7 series FPGAs and Zynq-7000 AP SoCs incorporate a new clocking structure as part of the clock management tile (CMT) called the Phaser that has all the built-in capabilities to control and maintain the clock-to-read-data timing with up to 7 ps precision.

[Figure 5](#) outlines the I/O block and CMT-to-logic fabric signal relationship that constitutes the basis of the PHY architecture. The system clock is driving the phase-locked loop (PLL) in the CMT, and that in turn drives the clock through the BUFG for the memory controller. A PLL output also drives the Phaser control and the PHASER_IN and PHASER_OUT blocks.

The PHASER_IN performs two primary functions: it delays the DQS, which is then used to capture the data (DQ in [Figure 5](#)) in the ISERDES; and it controls the transfer of the data from the ISERDES to the IN_FIFO block.

The FIFO has two modes, 1:2 and 1:1. The 1:2 mode further decouples the high data rates of the I/O from the logic fabric that needs to run at a lower rate. With the 1:4 ISERDES and 1:2 FIFO transfer ratios, the data is effectively running single data rate at $\frac{1}{4}$ of the memory clock rate. This is a necessity when implementing data rates higher than 1,600 Mb/s or 800 MHz. The memory controller needs to run only at $\frac{1}{4}$ of the 800 MHz rate. This 1:4 decoupling of the two clock systems (memory and controller) provides the benefit of easier timing closure. For 1.866 Gb/s data rates or 933 MHz clock rates, the memory controller runs at only 233 MHz. The logic-fabric-based controller state machine can meet timing if the clock rates are kept in this range.

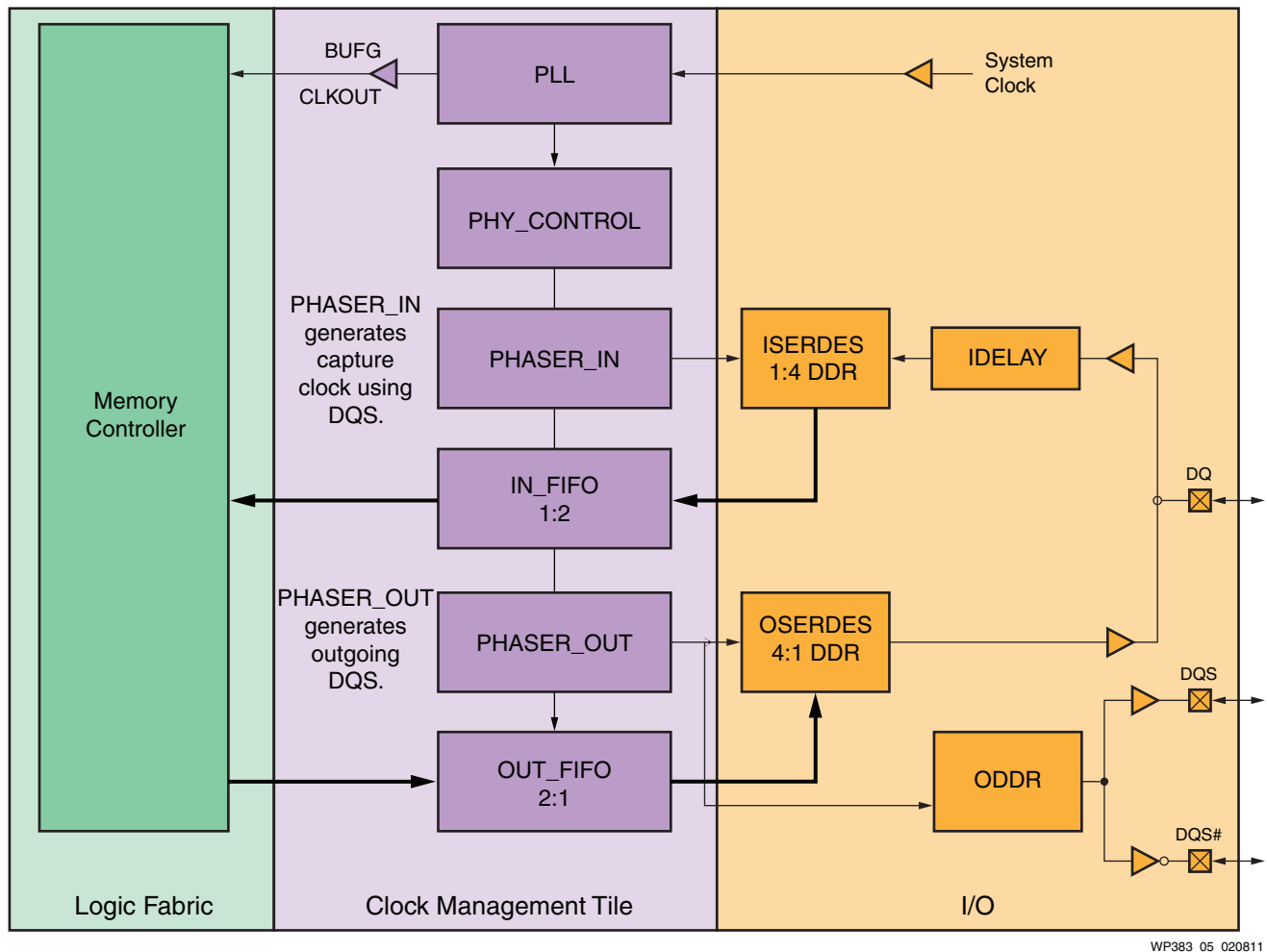

Figure 5: PHY Architecture and Data Transfer to the Logic-Fabric-Based Memory Controller

The output datapath and clocking are similar to the input path, but the PHASER_OUT and OUT_FIFO are used to clock and control the data out transfer. The PHASER_OUT also controls the generation of the outgoing DQS signal.

Achieving Higher Performance with the DDR3 SDRAM Controller

The maximum data rate per pin is just one factor used to determine the performance of the memory interface. The effective or average bandwidth that determines the overall performance is a factor of data rate per pin, efficiency, and bus width.

Higher efficiency comes from enabling the reordering function of the DDR3 controller. It reorders reads and groups the reads and writes to more effectively use the data bus. Efficiency can be defined as the number of clock cycles transferring data divided by the total number of clock cycles. Or:

$$\text{Efficiency (\%)} = \frac{\text{Clock cycles transferring data}}{\text{Total clock cycles}} \times 100 \quad \text{Equation 1}$$

This is very important because designers might not always be able to simply increase the clock frequency to obtain more bandwidth. Implementing high clock frequency systems is sometimes costly and increases power consumption; failing to take advantage of the maximum bandwidth attainable for a particular clock frequency is not an optimal way to design. In some systems, if the controller is not effectively using

the data bus, the actual bandwidth can drop to as low as 10% of the maximum capability. If a string of RWRW commands are placed on the bus, the turnaround time introduces a lot of dead cycles or gaps. Additionally, if the read or write commands are not accessing existing open rows, the pre-charge time can also add dead cycles. These dead cycles or gaps in the data bus are inherent to the way DDR3 SDRAMs operate and can be mitigated by a reordering controller.

To get maximum bandwidth, the controller needs to minimize RWRW accesses to the DDR3 SDRAM as well as maximize accesses to open rows. The Xilinx 28 nm portfolio's DDR3 controller leverages the Virtex-6 FPGA DDR3 controller's reordering architecture, which has already been successfully proven in mass-production systems. With an incoming command queue that possesses the added intelligence to reorder the user commands, the controller can do the following:

- Reorder alternating RWRW accesses by grouping reads and writes to minimize bus turnaround time
- Reorder reads to minimize page misses, thereby causing more commands to access open rows

Additionally, the user has the option to turn off the reordering controller mode and implement a strict order if needed.

Testing the Reordering DDR3 Controller

Typical streaming access patterns, like the reads with page hits, have high efficiency, but not all access patterns to the DDR3 memory exhibit this behavior. Non-streaming patterns have a lower efficiency, and for these patterns, the reordering controller can significantly improve the efficiency.

To quantify these efficiency improvements, several difficult test patterns were implemented with the DDR3 controller and then compared with the reordering feature on and with variable bank machines (queue depth).

Table 1 shows how difficult patterns like the random and alternating read/write patterns can drastically reduce the data bus efficiency, but the Xilinx DDR3 reordering controller can improve the bandwidth by up to 2X more than the in-order controller implementation. The DDR3 reordering controller used in the benchmarks has a queue of up to eight commands or "bank machines."

Table 1: Bandwidth Efficiency and Improvements with Xilinx Reordering Controller

Memory Clock (MHz)	Reordering Feature	# of Bank Machines (Queue Depth)	Streaming Page Hit Read	Page Hit Random Read/Write (Dual Banks)	Page Hit Alternating Read/Write (Dual Banks)
800	OFF	8	90%	42%	27%
800	ON	8	90%	58%	57%
800	OFF	4	90%	37%	27%
800	ON	4	90%	47%	45%

User Interface Options for Higher Performance and Flexibility

Interfacing to the memory controller is done through a user interface that runs synchronously with the memory controller clock. With 7 series devices and Zynq-7000 AP SoCs, Xilinx offers two options for the user interface to provide added flexibility and higher performance for various applications, as illustrated in [Figure 6](#).

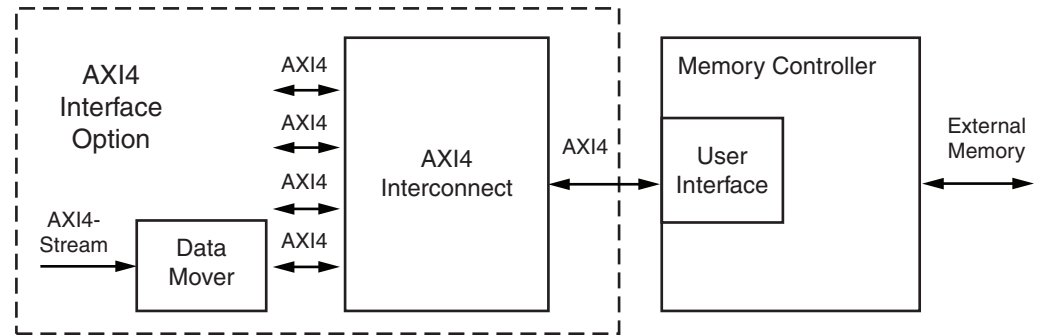

WP383_07_121410

Figure 6: Memory Controller User Interface Options in 7 Series Implementation

In applications where the external memory interface determines system performance, a single user port is typically preferred. One option offered in the 28 nm devices is the simple FIFO-based user interface, similar to the Virtex-6 FPGA implementation, running at the same clock rate as the controller.

The Advanced Microcontroller Bus Architecture (AMBA®4) AXI4 is a second option for applications where multiport or AXI4 compatibility is needed, such as in video or embedded applications. The AXI4 multiport function enables different users to share the memory controller through the AXI4 protocol. The AXI4 Interconnect block provides the connectivity required to support multiple ports or users accessing the controller or seamlessly connecting to other AXI4 IP. Furthermore, a data mover block can provide additional functionality to connect via AXI4-Stream. This AXI4 compatibility option is offered with comparable performance to the simple single-port user interface, but it can achieve much higher performance in embedded applications when compared to previous multi-port memory controller (MPMC) implementations. Refer to [WP379](#), *AXI4 Interconnect Paves the Way to Plug-and-Play IP* for further information on the AXI4 interconnect benefits.

Higher Productivity with the Memory Interface Generator (MIG)

A complete memory controller and interface design can be generated with the MIG wizard, a software tool freely available from Xilinx as part of the CORE Generator™ tool. The MIG design flow is similar to the traditional FPGA design flow. The benefit of the MIG tool is that there is no need to generate the RTL code from scratch for the PHY interface or the memory controller. The MIG wizard generates the RTL and UCF files, which are the HDL code and constraints files, respectively. These files are based on a library of hardware-verified IP, with modifications coming from the user's inputs. MIG produces the pre-verified IP with the necessary constraints that facilitate higher performance.

The designer has complete flexibility to further modify the RTL code or the constraints file. Unlike other solutions that offer black-box implementations, the MIG tool outputs unencrypted code, providing complete flexibility to change or further customize a design.

The MIG output files are categorized in modules that apply to different building blocks of the design: user interface, PHY, controller state machine, etc. The user has the option to also connect a different controller to the PHY generated by the MIG. Additionally, the MIG generates a synthesizable test bench with memory checker capability. The test bench is a design example used in the functional simulation and the hardware verification of the Xilinx base design. The test bench issues a series of writes and reads back to the memory controller. It can also be used as a template to generate a custom test bench, estimate the bandwidth efficiency, and therefore verify the expected performance for different memory access patterns.

Lower I/O Power for Memory Interfaces

High-performance systems cannot afford to burn unnecessary power, and memory interface I/Os are an important component of the total power consumption profile. With the 7 series and Zynq-7000 devices and the memory interface implementation, Xilinx has been able to reduce I/O power consumption to a minimum.

By dynamically turning off the input buffer during writes and idle cycles, power savings in the I/O block are achieved. Additionally, the internal termination (DCI) required for read operations is dynamically turned off during writes and idle times. Establishing V_{CCAUX} at 1.8V also significantly lowers the power consumption compared to the 2.5V used by competing 28 nm FPGA solutions.

For comparison, Table 2 shows the power consumed by a Kintex-7 FPGA and by a competing 28 nm solution in a typical 72-bit DDR3 interface with 50% read /50% write cycles at 1,600 Mb/s. The 1.9X higher I/O power consumed by the competing solution represents an additional 1.46W compared to the Xilinx solution.

Table 2: I/O Power Comparison for DDR3 Interfaces with 28 nm Devices

Device	Use Case	Memory Interface	I/O Power Consumed
Kintex-7 FPGA Solution	50% Read, 50% Write	72-bit DDR3 at 1,600 Mb/s	1.57W
Competing 28 nm Solution ⁽¹⁾			3.03W
Competing 28 nm solution versus Kintex-7 FPGA solution:			1.46W (1.9X) more power consumed

Notes:

1. The competing 28 nm solution's maximum data rate is limited to 1,600 Mb/s.

Hardware Verification and Characterization to Ensure Higher Performance

Hardware verification of memory interface and controller IP is an important final step to ensure a robust and reliable high-performance solution. Xilinx has verified memory interface designs and characterized them for several generations of products using a thorough characterization methodology with real system testing procedures. The characterization process is based on a multitude of tests that ensure process, voltage, and temperature (PVT) corners are tested in a real system environment that reaches stringent conditions similar to or surpassing actual user systems.

There are five categories of tests used in the characterization process:

- Voltage and Temperature Shmoo tests
- Read/Write channel tests
- Calibration stability tests
- JEDEC compliance tests
- Long Term Stability tests

For an actual demonstration of the DDR3 interface and controller with a mid-speed grade Kintex-7 device running at and above the 1,866 Mb/s specification using a Verification and Characterization board, visit:

<http://www.youtube.com/watch?v=-wT5VngccE>

Conclusion

Achieving higher performance for memory interfaces is a design process that starts from the ground up, with silicon features that enable higher maximum data rates and with memory controller features that enable higher efficiency with higher sustainable data rates. With Virtex-7, Kintex-7, and Zynq-7000 devices, Xilinx has developed the highest performance memory interface solution in the industry by maximizing the DDR3 data rate capability to 1.866 Gb/s for mid speed grade FPGAs and AP SoCs as well as improving the efficiency of the controller to sustain these high data rates in more demanding applications. Xilinx is also continuing to provide easy-to-use software tools, like MIG, that enable faster customization of the core IP. Xilinx memory interface solutions are based on extensive hardware characterization to ensure that high performance is sustainable in typical systems under changing voltage and temperature conditions.

Revision History

The following table shows the revision history for this document:

Date	Version	Description of Revisions
03/01/11	1.0	Initial Xilinx release.
08/14/12	1.1	Updated Testing the Reordering DDR3 Controller section. Added new section Lower I/O Power for Memory Interfaces . Updated Hardware Verification and Characterization to Ensure Higher Performance .
08/29/13	1.2	Incorporated Zynq-7000 devices. Updated Read Data Capture .

Notice of Disclaimer

The information disclosed to you hereunder (the "Materials") is provided solely for the selection and use of Xilinx products. To the maximum extent permitted by applicable law: (1) Materials are made available "AS IS" and with all faults, Xilinx hereby DISCLAIMS ALL WARRANTIES AND CONDITIONS, EXPRESS, IMPLIED, OR STATUTORY, INCLUDING BUT NOT LIMITED TO WARRANTIES OF MERCHANTABILITY, NON-INFRINGEMENT, OR FITNESS FOR ANY PARTICULAR PURPOSE; and (2) Xilinx shall not be liable (whether in contract or tort, including negligence, or under any other theory of liability) for any loss or damage of any kind or nature related to, arising under, or in connection with, the Materials (including your use of the Materials), including for any direct, indirect, special, incidental, or consequential loss or damage (including loss of data, profits, goodwill, or any type of loss or damage suffered as a result of any action brought by a third party) even if such damage or loss was reasonably foreseeable or Xilinx had been advised of the possibility of the same. Xilinx assumes no obligation to correct any errors contained in the Materials or to notify you of updates to the Materials or to product specifications. You may not reproduce, modify, distribute, or publicly display the Materials without prior written consent. Certain products are subject to the terms and conditions of Xilinx's limited warranty, please refer to Xilinx's Terms of Sale which can be viewed at <http://www.xilinx.com/legal.htm#tos>; IP cores may be subject to warranty and support terms contained in a license issued to you by Xilinx. Xilinx products are not designed or intended to be fail-safe or for use in any application requiring fail-safe performance; you assume sole risk and liability for use of Xilinx products in such critical applications, please refer to Xilinx's Terms of Sale which can be viewed at <http://www.xilinx.com/legal.htm#tos>.