



WP400 (v1.0) August 30, 2011

Addressing the Graphics Revolution for Automotive Instrumentation Design Using FPGAs

By: Nick Difiore

Automotive electronic content is continuing to grow at a robust pace, due in large part to consumer demand for safety, comfort, convenience, and entertainment. In the wake of that trend, the industry is witnessing a revolution in the design of the automotive instrument panel in step with the exponential increase in the amount of information available for communication to the driver and front-seat passenger. Engineers are leveraging FPGAs to drive these innovations to market faster.

FPGAs have reached a tipping point in terms of affordability that has elevated the technology from a rapid-prototyping tool to an affordable, flexible, high-volume production platform. In the case of the new generation of automotive instrument clusters, the FPGA can now provide the means for the business manager and product architect alike to reconcile the onslaught of varying function and performance requirements with the highly constrained engineering budgets that are a near-universal reality.

Configurable Clusters

One of the early enablers for increasing the information available to drivers was the advent of the thin-film transistor liquid-crystal display (TFT-LCD) for in-vehicle information and entertainment. The LCD enabled the use of a GUI that was easy to use and increased the level of information that could be communicated—much of it initially fueled by the emergence of GPS-based autonomous navigation systems.

With the transformation of the traditional instrument cluster (see [Figure 1](#)), the TFT-LCD is again disrupting what was once a very predictable design centering on electromechanical speedometer, tachometer, and fuel and temperature gauges, along with status and warning lights. This new and inherently flexible means of information display is providing a blank canvas for the automotive designer, subject to practical limitations imposed by the human-factors engineer.



WP400_01_072911

Figure 1: Traditional Electromechanical Gauges

Unlike traditional electromechanical instrumentation, the TFT-LCD allows for the dynamic organization of information. The driver can opt to have the system display only those gauges wanted at the moment, in real time, switching to others on the fly as needed. This new freedom has opened up an infinite number of design possibilities with respect to the overall function and style of dashboard instrumentation (see [Figure 2](#)).



Courtesy: Xylon

WP400_01_072511

Figure 2: Dynamic Automotive Instrument Display

Contrasting the Old and the New

The traditional cluster of dashboard instruments had a rather consistent architecture, in terms of electrical design and software (behavior), spanning the most basic cars to high-end luxury variants. Three main functional tasks were relatively straightforward:

- Gather vehicle and power-train status, including performance and diagnostic data, from the power-train controller and various sensors (directly, or through a vehicle network, or both)
- Control electromagnetic gauges (primarily stepper-motor-based) to display the proper real-time information.
- Display any relevant diagnostic or status information through warning indicators (e.g., turn signals and check-engine lights) or, in some cases, through a very limited (usually segmented) alphanumeric display, sometimes referred to as a message center.

The primary differentiators in traditional cluster designs are the overall mechanical packaging, gauge positioning, number of gauges, pointer shapes and colors, style of the fixed graphics, and lighting techniques. Designers have adopted some very sophisticated optical/mechanical techniques to get the "wow factor" in luxury products (for example, using reflected images to attain three-dimensional floating telltales or pointers). Nevertheless, the basic design elements outside of mechanical packaging remained the same for the most basic (economy vehicle) to the most complex (luxury car) models. A standardized electronic architecture, based on the use of a limited variety of semicustom microcontrollers, has been realistic and customary. [Figure 3](#) illustrates this traditional common architecture.

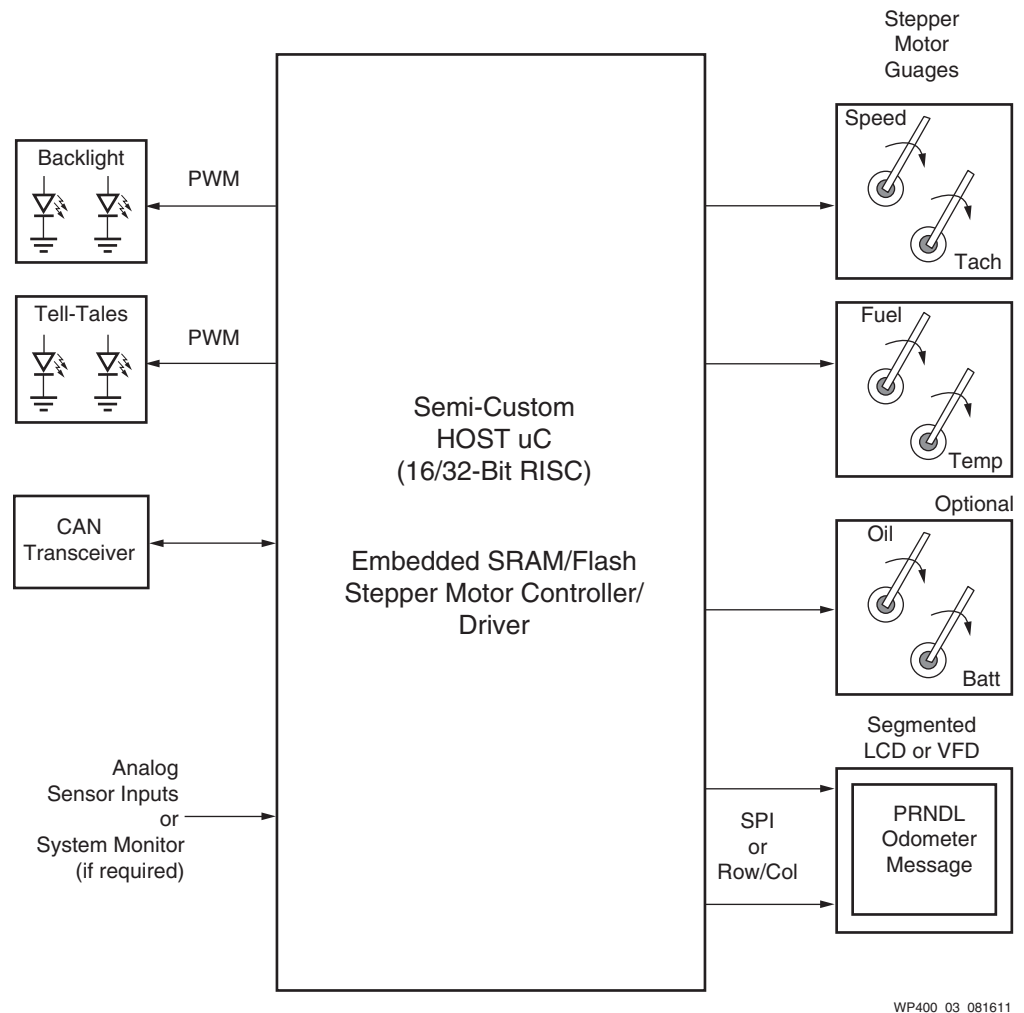

Figure 3: Traditional Cluster Architecture

With the newly affordable automotive-grade TFT-LCD display, the vehicle designer and human-factors engineer have an essentially free-form space in which to communicate virtually any type of information, in any format, with any design theme. Just as important, the strategy of what to display and how to display it can be changed dynamically. Driving is a very dynamic task with rapidly changing demands on awareness and attention level. The type and amount of information that makes sense to a driver, and thus adds value to a system, changes depending on whether the vehicle is parked, backing up, or driving in heavy stop-and-go traffic.

These demands mean that the instrument cluster engineer has much more data to collect based on the potential of a TFT display to communicate more information. In addition to the common controller-area network (CAN) connection, various other data sources (not available or suitable on CAN) also need to be considered. For example, the designer might want to display navigation or infotainment information directly in front of the driver, something impossible with mechanical gauges and lights and likely impractical with just a small message center. Displaying maps, navigation maneuver information, the song playing on the radio, or even an album cover is certainly possible now. Data might even include real-time images from a rear-view camera for parking assistance, since this can certainly be displayed on a TFT-LCD. All of these examples involve having the design flexibility to connect (or not, depending on the vehicle/option level) to a multimedia network or other digital

video streaming standards, including such technologies as MOST® devices, Ethernet AVB, or APIX.

The Task of Displaying the Information

The cluster engineer must address the virtually unlimited number of permutations that an auto OEM can now potentially use that combine older electromechanical gauge technology with the TFT-LCD. As cost grows rapidly with display size and resolution, different trade-offs and combinations of old and new make sense in a value-oriented compact car vs. a luxury sedan. Even luxury-focused OEMs, who might be convinced there is no longer a place for a mechanical gauge face, can question whether two (or more) smaller TFT displays might offer a lower cost than one larger one. In addition, the level of display capability, desired content, and level of graphic content/animation can all influence the requirements of the display controller hardware. Design variables include:

- Number of electromechanical gauges (stepper motor controllers/drivers), if any. These can range from none to as many as six or eight in some truck applications.
- Number and size of TFT-LCDs, which can include heads-up display (HUD) options.
- TFT-LCD resolution and color depth (a key cost driver in display and display controller selection). Automotive-grade displays generally range from QVGA (320 x 240 pixels) to Double WVGA (1,280 x 480 pixels).
- Number of graphics layers and type of alpha blending (varies with GUI concept and design style and typically ranges from two to as many as eight).
- Graphics capability and acceleration employed (for example, 2D, 2.5D, or 3D).
- Graphics performance in terms of display/object update rates, driven by the need for animation.
- Ability to capture, scale, process, and overlay video (for example, park assist or entertainment).
- Overall software compatibility complexity (e.g., type of graphics library/APIs employed, and compatibility with GUI development tools).
- Overall embedded-processor performance needs, which can range from 32-bit RISC for simple TFT-LCD message centers to superscalar multicore processors for a PC-like 3D experience.
- Overall memory performance and technology needed for video/graphics, which can range from low-cost, low-performance SDRAM to DDR3—the type of memory used in state-of-the-art PCs.

OEMs use these options to differentiate their vehicles or to give different models in their lineups their own distinct personalities. As a result, the cluster architect has to be prepared for the onslaught of fragmented customer requirements. One approach is to move from the traditional standard or semicustom microcontroller (based on programmable software) to a more dynamic, scalable platform based on programmable hardware.

The Programmable Advantage

In terms of reprogrammability, no alternative devices can match the flexibility of an FPGA. In the dashboard instrumentation application, in particular, the FPGA provides the automotive business manager with a means to limit the number of platform architectures the product architect must develop and maintain, while enabling the flexibility needed to adapt to increasingly fragmented OEM requirements and strategies. [Figure 4](#) illustrates the capability and flexibility of FPGA technology.

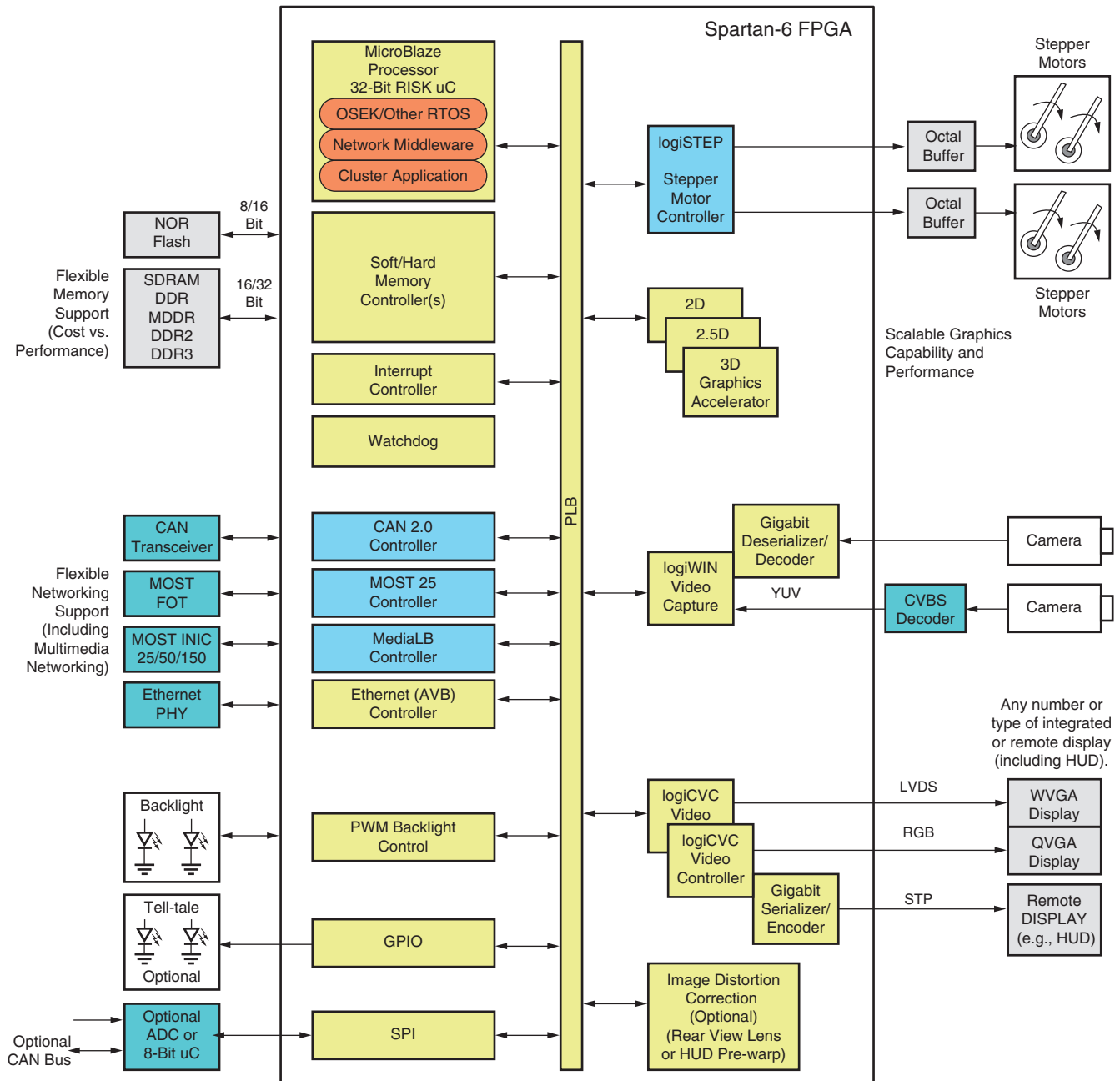

WP400_04_081611

Figure 4: FPGA-Based Cluster Platform

In [Figure 4](#), Xilinx® Automotive (XA) Spartan®-6 FPGA devices offer several key advantages, including:

- Hardened memory controller blocks for cost-effective high-performance DDR, DDR2, or DDR3 memory access, which is critical for high-performance graphics-based systems. In [Figure 4](#), memory throughputs as high as 3.2 Gb/s are possible.
- High-speed I/O options including Gigabit LVDS and serial transceivers (with operation up to 3.2 Gb/s) that enable the integration of automotive-grade remote digital video/display links, such as APIX.
- An array of available packages and logic densities allow a single platform to scale, yielding product derivatives with a range of features and cost. Single-PCB designs are possible due to the availability of several logic densities in board- and pin-compatible packaging.
- Fully automotive-qualified XA device line (tested beyond the latest AEC-Q100 standards) with support for OEM-required Production Part Approval Process (PPAP) and full BOM, manufacturing site, and change controls.

While putting the FPGA at the center of the architecture can certainly maximize flexibility, there is also an opportunity to leverage programmable hardware as a bridge between mature cluster designs and new cluster requirements. [Figure 5](#) shows how an automaker can use an FPGA to optionally extend the capability of a legacy cluster design into the TFT-LCD realm and also provide a means for multimedia network access. This is an attractive approach for addressing the transition to TFT-LCDs, while minimizing time to market and investment by leveraging mature, proven designs for the traditional cluster elements (e.g., sensor/network connectivity and electromagnetic gauge control). The added ability to create an embedded processor (namely, the MicroBlaze™ processor) on the FPGA, in this example, allows the FPGA to run application-specific graphics software. This can avoid overtasking the host microprocessor as well as minimizing the risk and expense of making major modifications to the legacy host processor software.

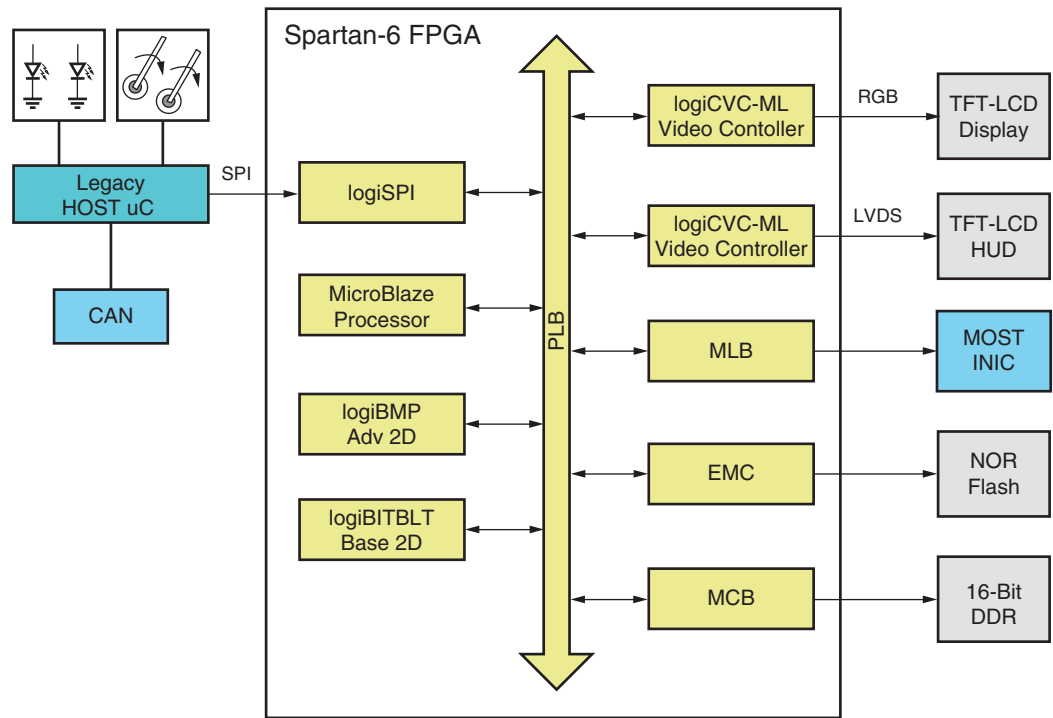

WP400_05_081711

Figure 5: **FPGA-Based Hybrid Cluster**

Combined with available third-party IP (e.g., Xylon logicBRICKS) and comprehensive hardware/software design tools, XA Spartan-6 FPGAs form the basis of a design platform that can help tier-one automotive suppliers eliminate the cost and risk associated with semicustom silicon and adapt to virtually any instrument cluster configuration with varying feature and performance levels, all at a cost that was unimaginable for programmable logic just a few years ago.

Zynq-7000 EPPs

The Zynq™-7000 extensible processing platform (EPP) is a new class of device recently announced by Xilinx (see Figure 6). This product combines a traditional, state-of-the-art, ARM® based processor system (well-known to many automotive software engineers) with the added flexibility of an FPGA (referred to as the programmable logic, or PL). A series of compatible devices provide for a range of FPGA resource levels and price points. The monolithic combination of these two sophisticated technologies offers embedded-processing performance far in excess of what can be achieved in "soft" FPGA-based microcontrollers alone—as well as virtually unlimited possibilities for software acceleration or peripheral/network connectivity that might be needed for data gathering, processing and display. As instrument clusters move into the PC-like realm in terms of information processing and display capability, EPPs open a new frontier for addressing this increasingly cost-sensitive, and flexibility-starved, automotive system.

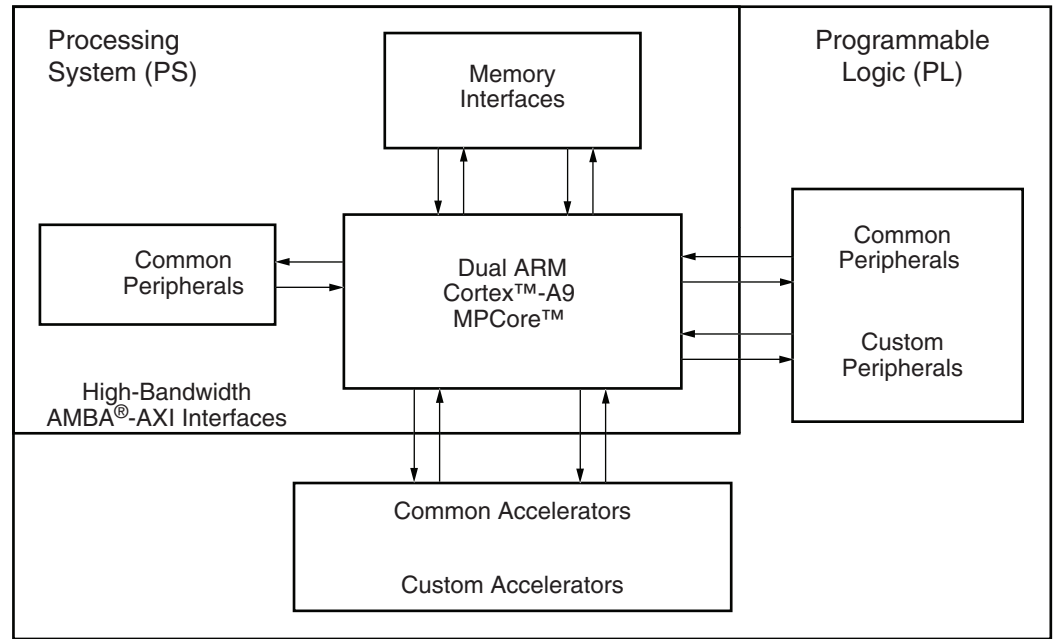

WP400_06_081811

Figure 6: Zynq-7000 EPP

Conclusion

It is clear that the GUI approach in driver information systems is increasing the complexity of the traditional instrument cluster. With this complexity comes a new challenge: managing the increasing complexity and fragmentation of OEM requirements. One approach for managing the engineering cost associated with such an increase is moving from a traditional microcontroller (i.e., software-based) approach to one where both software and hardware can be optimized and modified for specific product derivatives, all within a single platform design or product architecture. A new frontier in programmability enabled by the emergence of affordable field-programmable logic is fast becoming a realistic means for achieving that goal.

For more information, go to:

<http://www.xilinx.com/applications/automotive/high-resolution-video-and-graphics/index.htm>

Revision History

The following table shows the revision history for this document:

Date	Version	Description of Revisions
08/30/11	1.0	Initial Xilinx release.

Notice of Disclaimer

The information disclosed to you hereunder (the “Materials”) is provided solely for the selection and use of Xilinx products. To the maximum extent permitted by applicable law: (1) Materials are made available “AS IS” and with all faults, Xilinx hereby DISCLAIMS ALL WARRANTIES AND CONDITIONS, EXPRESS, IMPLIED, OR STATUTORY, INCLUDING BUT NOT LIMITED TO WARRANTIES OF MERCHANTABILITY, NON-INFRINGEMENT, OR FITNESS FOR ANY PARTICULAR PURPOSE; and (2) Xilinx shall not be liable (whether in contract or tort, including negligence, or under any other theory of liability) for any loss or damage of any kind or nature related to, arising under, or in connection with, the Materials (including your use of the Materials), including for any direct, indirect, special, incidental, or consequential loss or damage (including loss of data, profits, goodwill, or any type of loss or damage suffered as a result of any action brought by a third party) even if such damage or loss was reasonably foreseeable or Xilinx had been advised of the possibility of the same. Xilinx assumes no obligation to correct any errors contained in the Materials or to notify you of updates to the Materials or to product specifications. You may not reproduce, modify, distribute, or publicly display the Materials without prior written consent. Certain products are subject to the terms and conditions of the Limited Warranties which can be viewed at <http://www.xilinx.com/warranty.htm>; IP cores may be subject to warranty and support terms contained in a license issued to you by Xilinx. Xilinx products are not designed or intended to be fail-safe or for use in any application requiring fail-safe performance; you assume sole risk and liability for use of Xilinx products in Critical Applications: <http://www.xilinx.com/warranty.htm#critapps>.

AUTOMOTIVE APPLICATIONS DISCLAIMER

XILINX PRODUCTS ARE NOT DESIGNED OR INTENDED TO BE FAIL-SAFE, OR FOR USE IN ANY APPLICATION REQUIRING FAIL-SAFE PERFORMANCE, SUCH AS APPLICATIONS RELATED TO: (I) THE DEPLOYMENT OF AIRBAGS, (II) CONTROL OF A VEHICLE, UNLESS THERE IS A FAIL-SAFE OR REDUNDANCY FEATURE (WHICH DOES NOT INCLUDE USE OF SOFTWARE IN THE XILINX DEVICE TO IMPLEMENT THE REDUNDANCY) AND A WARNING SIGNAL UPON FAILURE TO THE OPERATOR, OR (III) USES THAT COULD LEAD TO DEATH OR PERSONAL INJURY. CUSTOMER ASSUMES THE SOLE RISK AND LIABILITY OF ANY USE OF XILINX PRODUCTS IN SUCH APPLICATIONS.